

## Ruud High Efficiency Air Handler



### RH1T (Piston) Series Constant Torque Motor (ECM) Efficiencies up to 14 SEER



- The RH1T feature a Constant Torque motor (ECM) and a piston refrigerant control for efficient and reliable operation.
- Versatile 4-way convertible design for upflow, downflow, horizontal left and horizontal right applications.
- Factory-installed indoor coil.
- Sturdy cabinet construction with 1.0 inch [25.4 mm] of foil faced insulation for excellent sound and insulating characteristics.
- Field-installed auxiliary electric heater kits provide exact heat for indoor comfort. Kits include circuit breakers which meet U.L. and cUL requirements for service disconnect.
- 1<sup>1</sup>/<sub>2</sub> ton [5.3 kW] through 5 ton [17.6 kW] models are between 42<sup>1</sup>/<sub>2</sub> to 57 inches [1080 to 1448 mm] tall and 22 inches [559 mm] deep.
- All models meet or exceed 330 to 400 CFM [156 to 189 L/s] per ton at .3 inches [.7 kPa] of external static pressure.
- Enhanced airflow up to .7" external static pressure.
- Evaporator is constructed of aluminum fins bonded to internally grooved aluminum tubing.
- Suitable for application in mobile homes.



# TABLE OF CONTENTS

Engineering Features .....	3
Model Number Identification .....	4
Dimensional Data .....	5-6
Airflow Directional Data .....	7
Airflow Performance Data RH1T .....	8-10
Electrical Data RH1T .....	11-13
Electrical Wiring .....	14
Accessories .....	14
Limited Warranty .....	15

## Engineering Features

### RH1T (Piston) Series

- The most compact unit design available, all standard heat air handler models only 42<sup>1</sup>/<sub>2</sub> to 57 inches [1079 to 1448 mm] high.
- Attractive pre-painted cabinet exterior.
- Rugged wall steel cabinet construction, designed for added strength and versatility.
- 1.0" foil faced insulation mechanically retained in blower compartment for excellent thermal and sound performance.
- Four leg blower motor mount.
- Blower housing with controls, motor and blower. Slide out design for service and maintenance convenience.
- Traditional open wire element design for heat applications.
- Field convertible for vertical downflow, horizontal left hand or right hand air supply.
- 3 combustible floor base accessories fit all model sizes when required for downflow installations on combustible floors.
- Indoor coil design provides low air side pressure drop, high performance and extremely compact size.
- Piston refrigerant control on indoor coil provides for reliable operation when matched with the RP14 Piston Heat Pump.
- Coils are constructed of aluminum fins bonded to internally grooved aluminum tubing.
- Coils are tested at the factory with an extensive refrigerant leak check.
- Coils have copper sweat refrigerant connections.
- Coils utilize chatleff metering device connections.
- Molded polymer corrosion resistant condensate drain pan is provided on all indoor coils.
- Supply duct flanges provided as standard on air handler cabinet.
- Provisions for field electrical, connections available from either side or top of the air handler cabinet.
- Connection point for high voltage wiring is inside the air handler cabinet. Low voltage connection is made on the outside of the air handler cabinet.
- Concentric knockouts are provided for power connection to cabinet. Installer may pull desired hole size up to 2 inches [51 mm] for 1<sup>1</sup>/<sub>2</sub> inch [38 mm] conduit.
- Front refrigerant and drain connections.

[ ] Designates Metric Conversions

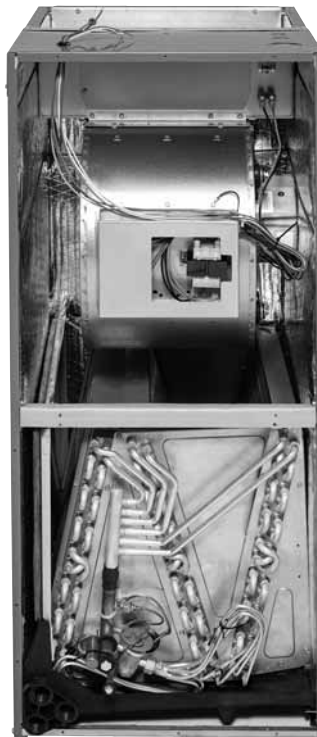

TXV Shown

**Model Number Identification**  
**RH1T (Piston) Series**

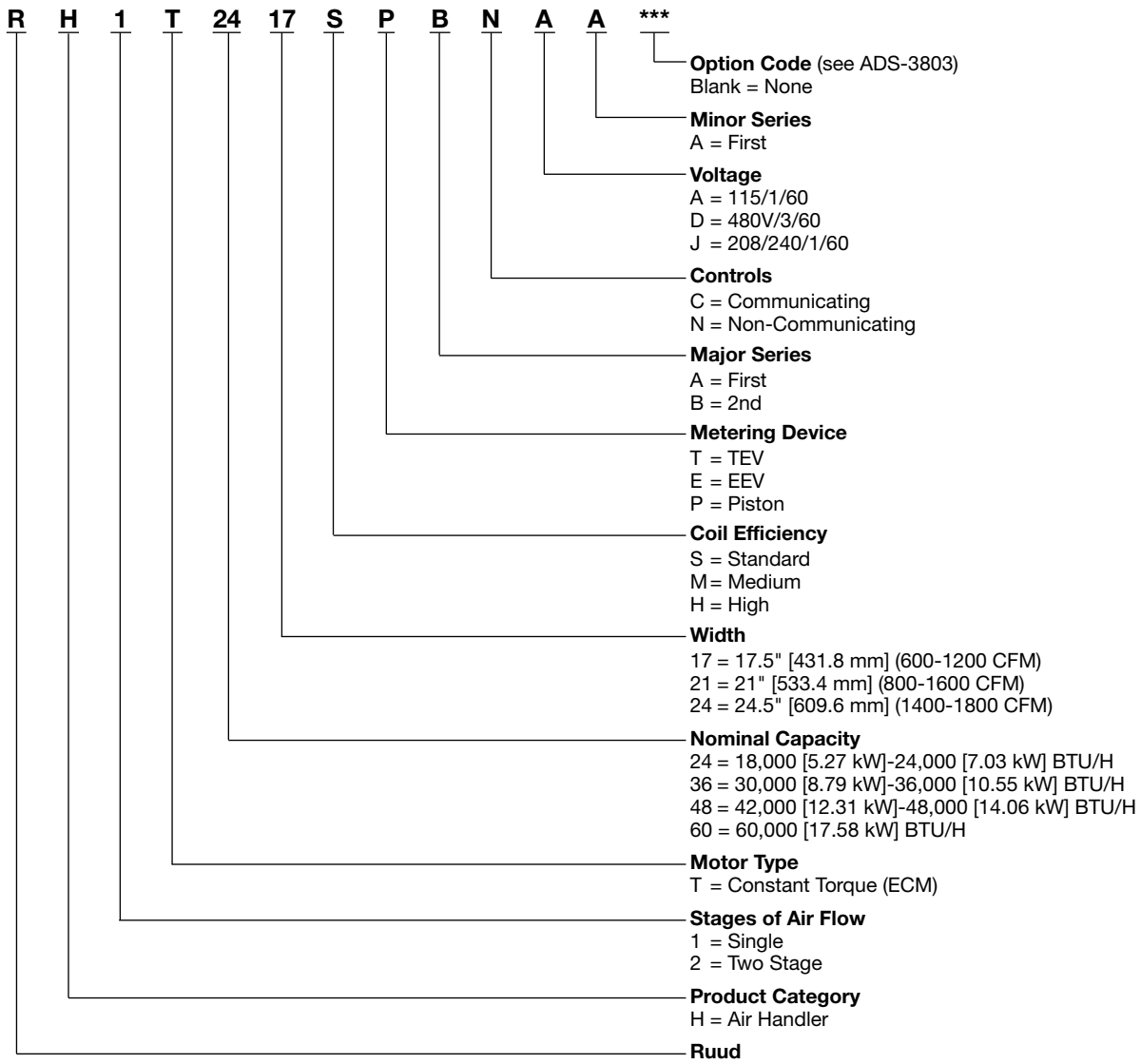

[ ] Designates Metric Conversions

<b>Available Models at 115V A Voltage</b>
RH1T2417SPBNAA
RH1T3617SPBNAA
RH1T4821SPBNAA

<b>Available Models at 208V J Voltage</b>
RH1T2417SPBNJA
RH1T3617SPBNJA
RH1T4821SPBNJA

# Unit Dimensions

ELECTRICAL CONNECTIONS  
MAY EXIT TOP OR EITHER SIDE  
HIGH VOLTAGE CONNECTION 7/8" [22.2 mm],  
1 3/32" [27.8 mm], 1 1/2" [50 mm] DIA. KNOCKOUTS.

LOW VOLTAGE CONNECTION  
3/4" [15.9 mm] AND 7/8" [22.2 mm] KNOCKOUT

AUXILIARY DRAIN CONNECTION  
3/4" [19.1 mm] FEMALE PIPE THREAD (NPT)  
HORIZONTAL APPLICATION ONLY

PRIMARY DRAIN CONNECTION  
3/4" [19.1 mm] FEMALE PIPE THREAD (NPT)

AUXILIARY DRAIN CONNECTION  
3/4" [19.1 mm] FEMALE PIPE THREAD (NPT)  
UPFLOW/DOWNFLOW APPLICATION ONLY

LIQUID LINE CONNECTION  
COPPER (SWEAT)

VAPOR LINE CONNECTION  
COPPER (SWEAT)

SUPPLY AIR ↑

NOTE: 24" CLEARANCE REQUIRED IN FRONT OF  
UNIT FOR FILTER AND COIL MAINTENANCE.

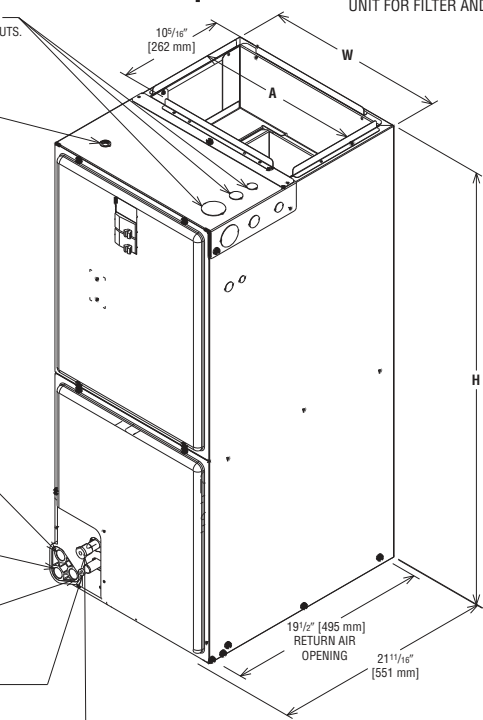

UPFLOW UNIT SHOWN:  
UNIT MAY BE INSTALLED UPFLOW, DOWNFLOW,  
HORIZONTAL RIGHT OR LEFT AIR SUPPLY.

## Return Air Opening Dimensions

Model Cabinet Size	Return Air Opening Width (Inches)	Return Air Opening Depth/Length (Inches)
17	15 7/8	19 3/4
21	19 3/8	19 3/4
24	22 7/8	19 3/4

HORIZONTAL ADAPTER KIT

VAPOR LINE CONNECTION

AUXILIARY HORIZONTAL DRAIN CONNECTION

PRIMARY DRAIN CONNECTION

AUXILIARY UPFLOW/DOWNFLOW DRAIN CONNECTION

LIQUID LINE CONNECTION

VERTICAL DRAIN PAN

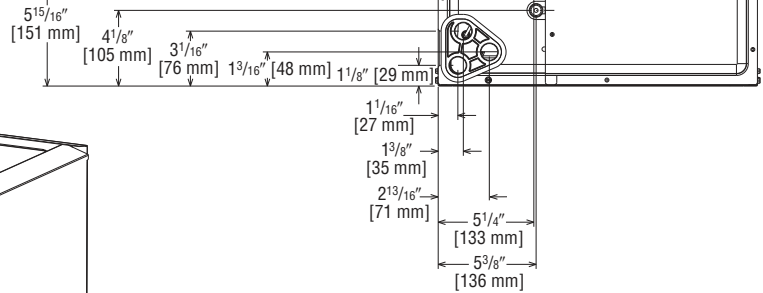

UPFLOW UNIT SHOWN:  
UNIT MAY BE INSTALLED UPFLOW,  
DOWNFLOW, HORIZONTAL RIGHT  
OR LEFT AIR SUPPLY.

[ ] Designates Metric Conversions

( ) Designates Unit with Double Coil Cabinet

**Unit Dimensions & Weights**

Model Size RH1T	Refrigerant Connections Sweat (In.) [mm] ID		Unit Width "W" In. [mm]	Unit Height "H" In. [mm]	Supply Duct "A" In. [mm]	Air Flow CFM (Nom.) [L/s]		Unit Weight/Shipping Weight (Lbs.) [kg]
	Liquid	Vapor				Lo	Hi	Unit With Coil (Max. KW)
2417SP	3/8 [9.53]	3/4 [19.05]	17 1/2 [445]	42 1/2 [1080]	16 [406]	600 [283]	800 [378]	92/106 [42/48]
3617SP	3/8 [9.53]	3/4 [19.05]	17 1/2 [445]	42 1/2 [1080]	16 [406]	1000 [472]	1200 [566]	96/110 [44/50]
4821SP	3/8 [9.53]	7/8 [22.23]	21 [533]	50 1/2 [1282]	19 1/2 [495]	1400 [661]	1600 [755]	128/144 [56/65]

\*Maximum dehumidification airflow.

[ ] Designates Metric Conversions

### Airflow Directional Data

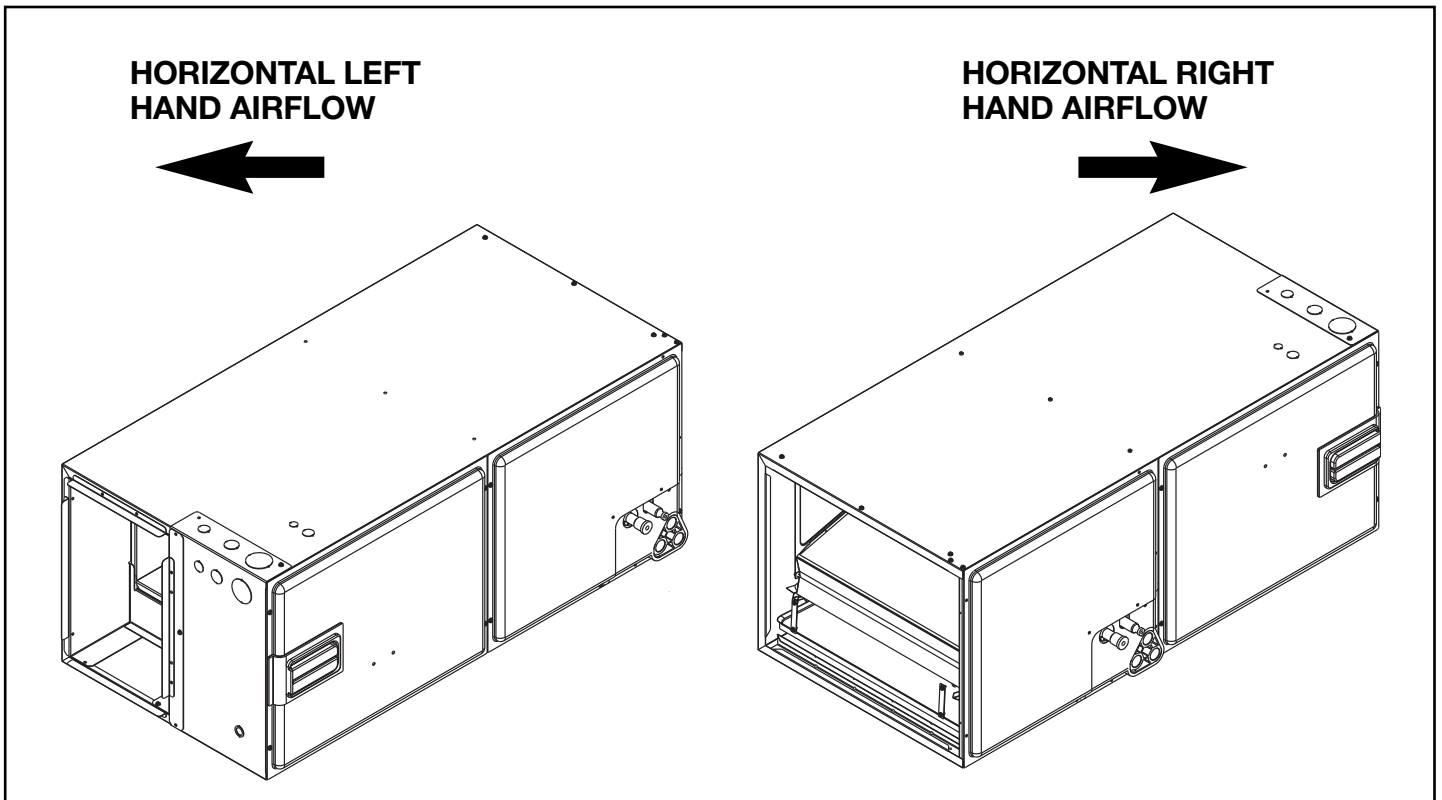
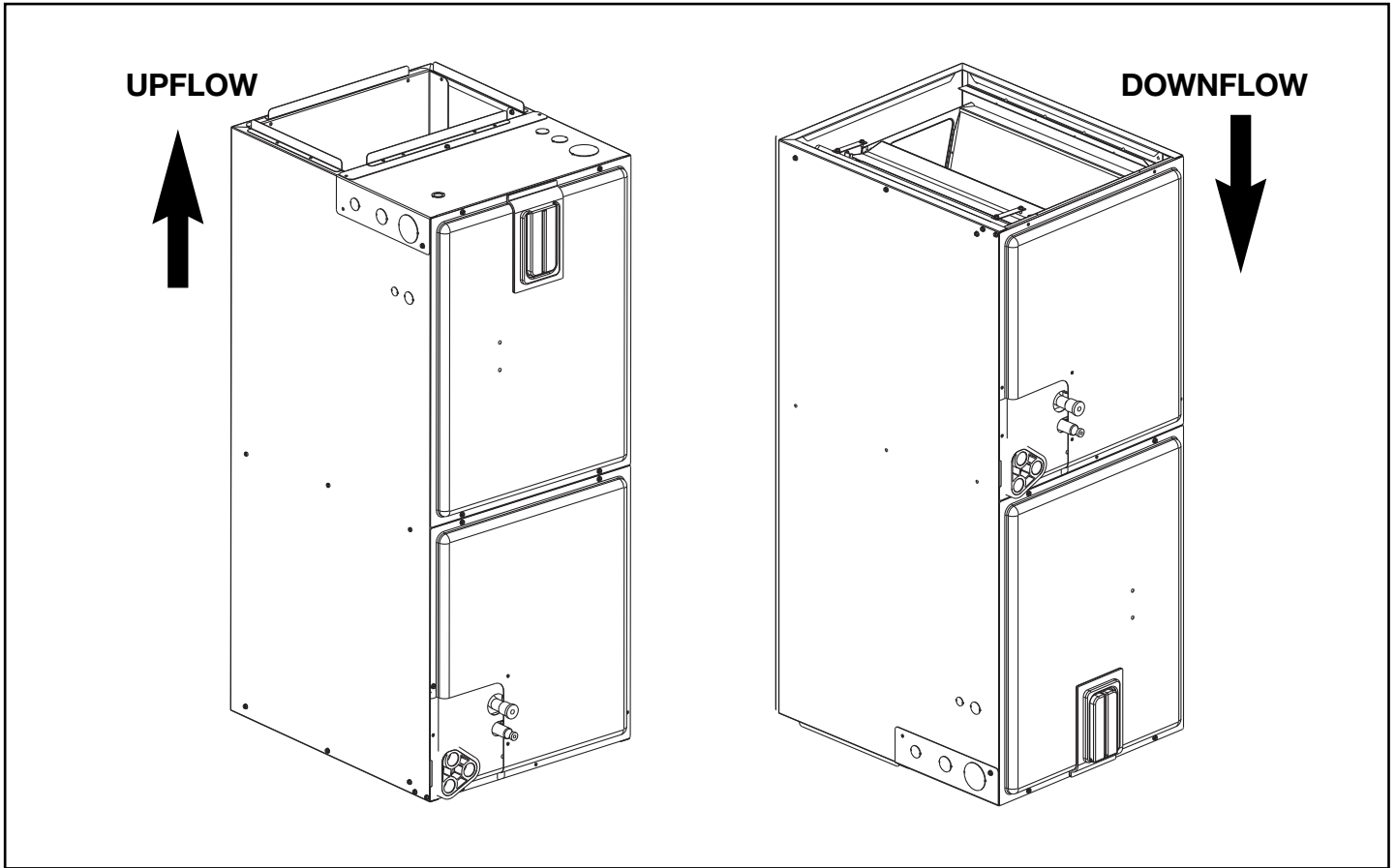

## Airflow Performance

**Airflow performance data is based on cooling performance with a coil and no filter in place.** Select performance table for appropriate unit size, voltage and number of electric heaters to be used. Make sure external static applied to unit allows operation within the minimum and maximum limits shown in table

below for both cooling and electric heat operation. For optimum blower performance, operate the unit in the .3 [8 mm] to .7 inches [18 mm] W.C. external static range. Units with coils should be applied with a minimum of .1 inch [3 mm] W.C. external static range.

## Airflow Operating Limits

Model Cabinet Width	17	17/21	21
Cooling BTUH x 1,000	-24	-36	-48
Cooling Tons Nominal	2	3	4
Heat Pump or Air Conditioning Maximum Heat/Cool CFM [L/s] (37.5 CFM [18 L/s]/1,000 BTUH) (450 CFM [212 L/s]/Ton Nominal)	900 [425]	1350 [637]	1800 [850]
Heat Pump or Air Conditioning Nominal Heat/Cool CFM [L/s] (33.3 CFM [16 L/s]/1,000 BTUH) (400 CFM [189 L/s]/Ton Nominal)	800 [378]	1200 [566]	1600 [755]
Heat Pump or Air Conditioning Minimum Heat/Cool CFM [L/s] (30.0 CFM [14 L/s]/1,200 BTUH) (360 CFM [170 L/s]/Ton Nominal)	720 [340]	1080 [510]	1440 [680]
Maximum kW Electric Heating & Minimum Electric Heat CFM [L/s]	13 617 [291]	18 1054 [497]	25 1502 [709]
Maximum Electric Heat Rise °F [°C]	63 [17.2]	51 [10.6]	50 [10]

[ ] Designates Metric Conversions



### 115V/208V/240V Airflow Performance Data—RH1T (Piston)

Model No. RH1T	Tonnage Application	Motor Speed From Factory	Manufacturer Recommended Air-Flow Range (Min/Max) CFM	Blower Size/ Motor HP [W] # of Speed	Motor Speed	c									
						External Static Pressure—Inches W.C. [kPa]									
						0.1 [.02]	0.2 [.05]	0.3 [.07]	0.4 [.10]	0.5 [.12]	0.6 [.15]	0.7 [.17]			
2417SP No Heat	1.5 Ton	5	683/485 [322/229 L/s]	10x8 1/3 HP [249] 5 Speed	2	CFM	837 [395]	713 [366]	608 [287]	554 [261]	485 [229]	—	—		
						RPM	565	587	630	692	751	—	—		
						Watts	95	81	88	74	66	—	—		
					3	CFM	—	—	—	—	683 [322]	615 [290]	572 [270]	—	—
						RPM	—	—	—	—	789	842	892	—	—
						Watts	—	—	—	—	140	159	155	—	—
2417SP with 13 kW Heater	1.5 Ton	5	683/485 [322/229 L/s]	10x8 1/3 HP [249] 5 Speed	2	CFM	814 [384]	692 [326]	589 [278]	535 [252]	467 [220]	—	—		
						RPM	592	613	656	719	778	—	—		
						Watts	108	90	97	82	73	—	—		
					3	CFM	—	—	—	—	808 [381]	629 [297]	584 [276]	—	—
						RPM	—	—	—	—	789	842	892	—	—
						Watts	—	—	—	—	148	168	163	—	—
2417SP No Heat	2 Ton	5	858/697 [405/329 L/s]	10x8 1/3 HP [249] 5 Speed	4	CFM	902 [426]	846 [399]	788 [372]	742 [350]	679 [320]	—	—		
						RPM	596	645	694	741	791	—	—		
						Watts	105	108	116	121	130	—	—		
					5	CFM	—	—	—	—	858 [276]	816 [385]	770 [363]	—	—
						RPM	—	—	—	—	834	879	925	—	—
						Watts	—	—	—	—	185	182	214	—	—
2417SP with 13 kW Heater	2 Ton	5	683/485 [322/229 L/s]	10x8 1/3 HP [249] 5 Speed	4	CFM	882 [416]	827 [390]	769 [363]	723 [341]	661 [312]	—	—		
						RPM	595	670	719	767	817	—	—		
						Watts	113	125	124	129	197	—	—		
					5	CFM	—	—	—	—	833 [393]	791 [373]	746 [352]	—	—
						RPM	—	—	—	—	852	898	944	—	—
						Watts	—	—	—	—	192	189	222	—	—
3617SP No Heater	2.5 Ton	5	935/1084 CFM [441/512 L/s]	10x8 1/2 HP [373] 5 Speed	2	CFM	1093 [516]	1050 [496]	1017 [480]	977 [461]	935 [441]	—	—		
						RPM	671	725	764	809	852	—	—		
						Watts	153	168	174	180	188	—	—		
					3	CFM	—	—	—	—	1084 [512]	1040 [491]	1001 [472]	—	—
						RPM	—	—	—	—	896	936	971	—	—
						Watts	—	—	—	—	249	257	261	—	—
3617SP with 18 kW Heater	2.5 Ton	5	910/1059 CFM [429/500 L/s]	10x8 1/2 HP [373] 5 Speed	2	CFM	1068 [504]	1025 [484]	992 [468]	952 [449]	910 [429]	—	—		
						RPM	711	765	804	849	892	—	—		
						Watts	164	179	185	191	199	—	—		
					3	CFM	—	—	—	—	1059 [500]	1015 [479]	976 [461]	—	—
						RPM	—	—	—	—	936	976	1011	—	—
						Watts	—	—	—	—	260	268	272	—	—
3617SP No Heater	3 Ton	5	1130/1275 CFM [533/602 L/s]	10x8 1/2 HP [373] 5 Speed	4	CFM	1270 [599]	1237 [584]	1199 [566]	1165 [550]	1130 [533]	—	—		
						RPM	775	816	846	882	926	—	—		
						Watts	237	249	259	268	277	—	—		
					5	CFM	—	—	—	—	1275 [602]	1244 [587]	1211 [571]	—	—
						RPM	—	—	—	—	963	999	1029	—	—
						Watts	—	—	—	—	338	348	363	—	—
3617SP with 18 kW Heater	3 Ton	5	1105/1250 CFM [521/590 L/s]	10x8 1/2 HP [373] 5 Speed	4	CFM	1245 [588]	1212 [572]	1174 [554]	1140 [538]	1105 [521]	—	—		
						RPM	815	856	886	922	966	—	—		
						Watts	248	260	270	279	288	—	—		
					5	CFM	—	—	—	—	1250 [590]	1219 [575]	1186 [560]	—	—
						RPM	—	—	—	—	1003	1039	1069	—	—
						Watts	—	—	—	—	349	359	374	—	—

[ ] Designates Metric Conversions

## 115V/208V/240V Airflow Performance Data—RH1T (Piston) (con't.)

Model No. RH1T	Tonnage Application	Motor Speed From Factory	Manufacturer Recommended Air-Flow Range (Min/Max) CFM	Blower Size/ Motor HP [W] # of Speed	Motor Speed	CFM [L/s] Air Delivery/RPM/Watts (No Filter)							
						External Static Pressure—Inches W.C. [kPa]							
						0.1 [.02]	0.2 [.05]	0.3 [.07]	0.4 [.10]	0.5 [.12]	0.6 [.15]	0.7 [.17]	
4821SP No Heater	3.5 Ton	5	1337/1447 CFM [631/683 L/s]	10x10 3/4 HP [559] 5 Speed	2	CFM	1473 [695]	1442 [681]	1401 [661]	1373 [648]	1337 [631]	—	—
						RPM	781	825	867	905	949	—	—
						Watts	257	271	303	307	315	—	—
					3	CFM	—	—	—	—	1447 [683]	1433 [676]	1402 [662]
						RPM	—	—	—	—	987	1034	1065
						Watts	—	—	—	—	394	406	405
4821SP with 20 kW Heater	3.5 Ton	5	1297/1333 CFM [612/629 L/s]	10x10 3/4 HP [559] 5 Speed	2	CFM	1433 [676]	1402 [662]	1361 [642]	1333 [629]	1297 [612]	—	—
						RPM	831	875	919	954	989	—	—
						Watts	277	295	313	319	325	—	—
					3	CFM	—	—	—	—	1333 [629]	1300 [613]	1267 [598]
						RPM	—	—	—	—	1011	1046	1080
						Watts	—	—	—	—	350	364	377
4821SP No Heater	4 Ton	5	1535/1654 CFM [724/781 L/s]	10x10 3/4 HP [559] 5 Speed	4	CFM	1665 [786]	1631 [770]	1601 [756]	1572 [742]	1535 [724]	—	—
						RPM	853	893	934	968	1015	—	—
						Watts	351	387	401	406	422	—	—
					5	CFM	—	—	—	—	1654 [781]	1624 [766]	1563 [738]
						RPM	—	—	—	—	1036	1078	1095
						Watts	—	—	—	—	500	513	523
4821SP with 25 kW Heater	4 Ton	5	1495/1614 CFM [706/762 L/s]	10x10 3/4 HP [559] 5 Speed	4	CFM	1625 [767]	1591 [751]	1561 [737]	1532 [723]	1495 [706]	—	—
						RPM	894	932	970	1020	1052	—	—
						Watts	389	400	410	430	450	—	—
					5	CFM	—	—	—	—	1614 [762]	1584 [748]	1523 [719]
						RPM	—	—	—	—	1085	1090	1105
						Watts	—	—	—	—	514	520	530

- Notes:
- All 208/240V PSC motors have voltage taps for 208 and 240 volts.
  - All 208/240V PSC motors are shipped on high speed and 240 volts.
  - If the application external static is less than 0.5" WC, adjust the motor speed to the low static speed as described below:
    - Unplug the black motor wire off the relay on the control board and plug in the red motor wire.
    - Replace the cap on the black motor wire.
  - Voltage change (208/240V motors):
    - Move the orange lead to transformer 208V tap from 240V tap. Replace the wire cap on 240V tap.
    - Unplug the purple motor wire off the transformer and plug in the yellow motor wire.
    - Replace the cap on the purple motor wire.
  - The above airflow table lists the airflow information for air handlers without heater and air handler with maximum heater allowed for each model.
  - The following formula can be used to calculate the approximate airflow, if a smaller (N kW) than the maximum heater kit is installed.  
 Approximate Airflow = Airflow without heater - (Airflow without heater - Airflow with maximum heater) x (N kW/maximum heater kW)

[ ] Designates Metric Conversions

## Electrical Data – Blower Motor Only – No Electric Heat RH1T (Piston)

Model RH1T	Voltage	Application Phase*	Hertz	HP [W]	RPM	Speeds	Circuit Amps.	Minimum Circuit Ampacity	Maximum Circuit Protector
2417SP	208/240	1 & 3	60	1/3 [249]	300-1100	4	1.6	2	15
3617SP				1/2 [373]	300-1100	4	2.7	4	15
4821SP				3/4 [559]	300-1100	4	3.8	5	15
2417SP	115	1	60	1/3 [249]	300-1100	4	4.8	6	15
3617SP				1/2 [373]	300-1100	4	6.8	9	15
4821SP				3/4 [559]	300-1100	4	8.4	11	15

\* Blower motors are all single phase motors.

[ ] Designates Metric Conversions

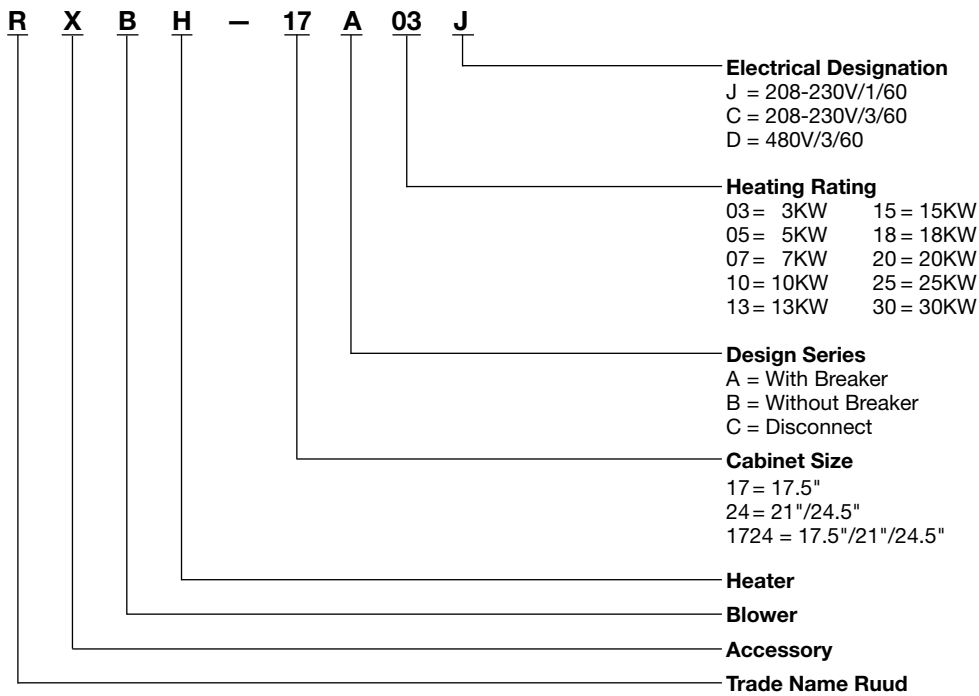

## Electrical Data – With Electric Heat RH1T (Piston)

Installation of the U.L. Listed original equipment manufacturer provided heater kits listed in the following table is recommended for all auxiliary heating requirements.

Air Handler Model RH1T	Heater Model No.	Heater kW (208/240V) (480V)	PH/HZ	No. Elements kW Per	Type Supply Circuit Single Circuit Multiple	Circuit Amps.	Motor Ampacity	Minimum Circuit Ampacity	Maximum Circuit Protector
2417SPAN	RXBH-17?03J	2.2/3	1/60	1 - 3	SINGLE	10.8/12.5	2.8	18/20	20/20
	RXBH-1724?05J	3.6/4.8	1/60	1 - 4.8	SINGLE	17.3/20	2.8	26/29	30/30
	RXBH-1724?07J	5.4/7.2	1/60	2 - 3.6	SINGLE	26/30	1.6	35/40	35/40
	RXBH-1724?10J	7.2/9.6	1/60	2 - 4.8	SINGLE	34.6/40	2.8	47/54	50/60
	RXBH-1724A10C	7.2/9.6	3/60	3 - 3.2	SINGLE	20/23.1	2.8	29/33	30/35
	RXBH-1724A13J	9.4/12.5	1/60	3 - 4.17	SINGLE	45.1/52.1	2.8	60/69	60/70
	RXBH-1724A13J	3.1/4.2	1/60	1 - 4.17	MULTIPLE CKT 1	15/17.4	2.8	23/26	25/30
	RXBH-1724A13J	6.3/8.3	1/60	2 - 4.17	MULTIPLE CKT 2	30.1/34.7	0	38/44	40/45
3617SPAN	RXBH-17?03J	2.2/3	1/60	1 - 3	SINGLE	10.8/12.5	4.1	19/21	20/25
	RXBH-1724?05J	3.6/4.8	1/60	1 - 4.8	SINGLE	17.3/20	4.1	27/31	30/35
	RXBH-1724?07J	5.4/7.2	1/60	2 - 3.6	SINGLE	26/30	4.1	38/43	40/45
	RXBH-1724?10J	7.2/9.6	1/60	2 - 4.8	SINGLE	34.6/40	4.1	49/56	50/60
	RXBH-1724A10C	7.2/9.6	3/60	3 - 3.2	SINGLE	20/23.1	4.1	31/35	35/35
	RXBH-1724A13J	9.4/12.5	1/60	3 - 4.17	SINGLE	45.1/52.1	4.1	62/71	70/80
	RXBH-1724A13J	3.1/4.2	1/60	1 - 4.17	MULTIPLE CKT 1	15/17.4	4.1	24/27	25/30
	RXBH-1724A13J	6.3/8.3	1/60	2 - 4.17	MULTIPLE CKT 2	30.1/34.7	0	38/44	40/45
	RXBH-1724A15C	10.8/14.4	3/60	3 - 4.8	SINGLE	30/34.6	4.1	43/49	45/50
	RXBH-1724A15J	10.8/14.4	1/60	3 - 4.8	SINGLE	51.9/60	4.1	70/81	70/90
	RXBH-1724A15J	3.6/4.8	1/60	1 - 4.8	MULTIPLE CKT 1	17.3/20	4.1	27/31	30/35
	RXBH-1724A15J	7.2/9.6	1/60	2 - 4.8	MULTIPLE CKT 2	34.6/40	0	44/50	45/50
	RXBH-1724A18J	12.8/17	1/60	3 - 5.67	SINGLE	61.6/70.8	4.1	83/94	90/100
	RXBH-1724A18J	4.3/5.7	1/60	1 - 5.67	MULTIPLE CKT 1	20.5/23.6	4.1	31/35	35/35
	RXBH-1724A18J	8.5/11.3	1/60	2 - 5.67	MULTIPLE CKT 2	41.1/47.2	0	52/60	60/60

- Supply circuit protective devices may be fuses or "HACR" type circuit breakers.
- Largest motor load is included in single circuit and multiple circuit 1.
- If non-standard fuse size is specified, use next size larger standard fuse size.
- J Voltage (230V) single phase air handler is designed to be used with single or three phase 230 volt electric heaters. In the case of connecting 3-phase power to the air handler terminal block without the heater, bring only two leads to the terminal block cap, insulate and fully secure the third lead.

[ ] Designates Metric Conversions

## Electrical Data – With Electric Heat RH1T (Piston) (Cont.)

Installation of the U.L. Listed original equipment manufacturer provided heater kits listed in the following table is recommended for all auxiliary heating requirements.

Air Handler Model RH1T	Heater Model No.	Heater kW (208/240V) (480V)	PH/HZ	No. Elements kW Per	Type Supply Circuit Single Circuit Multiple	Circuit Amps.	Motor Ampacity	Minimum Circuit Ampacity	Maximum Circuit Protector
4821SP	RXBH-1724A18J	12.8/17	1/60	3 - 5.67	SINGLE	61.6/70.8	4.1	83/94	90/100
	RXBH-1724A18J	4.3/5.7	1/60	1 - 5.67	MULTIPLE CKT 1	20.5/23.6	4.1	31/35	35/35
	RXBH-1724A18J	8.5/11.3	1/60	2 - 5.67	MULTIPLE CKT 2	41.1/47.2	0	52/60	60/60
	RXBH-24A20C	14.4/19.2	3/60	6 - 3.2	SINGLE	40/46.2	4.1	56/63	60/70
	RXBH-24A20C	7.2/9.6	3/60	3 - 3.2	MULTIPLE CKT 1	20/23.1	4.1	31/35	35/35
	RXBH-24A20C	7.2/9.6	3/60	3 - 3.2	MULTIPLE CKT 2	20/23.1	0	25/29	25/30
	RXBH-24A20J	14.4/19.2	1/60	4 - 4.8	SINGLE	69.2/80	4.1	92/106	100/110
	RXBH-24A20J	7.2/9.6	1/60	2 - 4.8	MULTIPLE CKT 1	34.6/40	4.1	49/56	50/60
	RXBH-24A20J	7.2/9.6	1/60	2 - 4.8	MULTIPLE CKT 2	34.6/40	0	44/50	45/50
	RXBH-24A25C	18/24	3/60	6 - 4	SINGLE	50/57.8	4.1	68/78	70/80
	RXBH-24A25C	9/12	3/60	3 - 4	MULTIPLE CKT 1	25/28.9	4.1	37/42	40/45
	RXBH-24A25C	9/12	3/60	3 - 4	MULTIPLE CKT 2	25/28.9	0	32/37	35/40
	RXBH-24A25J	18/24	1/60	6 - 4	SINGLE	86.4/99.9	4.1	114/130	125/150
	RXBH-24A25J	6/8	1/60	2 - 4	MULTIPLE CKT 1	28.8/33.3	4.1	42/47	45/50
	RXBH-24A25J	6/8	1/60	2 - 4	MULTIPLE CKT 2	28.8/33.3	0	37/42	40/45
RXBH-24A25J	6/8	1/60	2 - 4	MULTIPLE CKT 3	28.8/33.3	0	37/42	40/45	

- Supply circuit protective devices may be fuses or "HACR" type circuit breakers.
- Largest motor load is included in single circuit and multiple circuit 1.
- If non-standard fuse size is specified, use next size larger standard fuse size.
- J Voltage (230V) single phase air handler is designed to be used with single or three phase 230 volt electric heaters. In the case of connecting 3-phase power to the air handler terminal block without the heater, bring only two leads to the terminal block cap, insulate and fully secure the third lead.

[ ] Designates Metric Conversions

## Electrical Wiring

### Power Wiring

- Field wiring must comply with the National Electrical Code (C.E.C. in Canada) and any applicable local ordinance.
- Supply wiring must be 75°C minimum copper conductors only.
- See electrical data for product Ampacity rating and Circuit Protector requirement.

## Accessories

### • Combustible Floor Base RXHB-

Model Cabinet Size	Combustible Floor Base Model Number
17	RXHB-17
21	RXHB-21
24	RXHB-24

- **Jumper Bar Kit 3 Ckt. to 1 Ckt. RXBJ-A31** is used to convert single phase multiple three circuit units to a single supply circuit. Kit includes cover and screw for line side terminals.
- **Jumper Bar Kit 2 Ckt. to 1 Ckt. RXBJ-A21** is used to convert single phase multiple two circuit units to a single supply circuit. Kit includes cover and screw for line side terminals.
- **Note:** No jumper bar kit is available to convert three phase multiple two circuit units to a single supply circuit.

### • Auxiliary Horizontal Overflow Pan Accessory RXBM-

Nominal Cooling Capacity-Tons	Auxiliary Horizontal Overflow Pan Accessory Model Number
1 <sup>1</sup> / <sub>2</sub> - 3	RXBM-AC48
3 <sup>1</sup> / <sub>2</sub> - 5	RXBM-AC61

[ ] Designates Metric Conversions

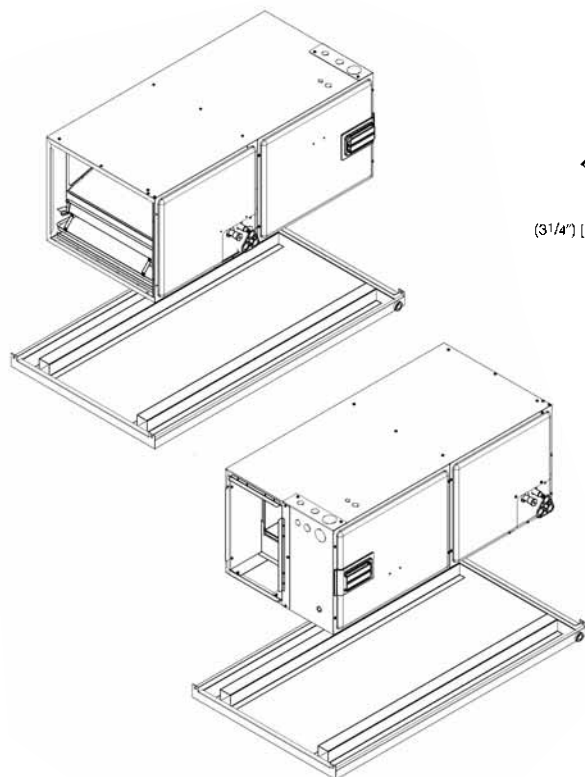

### Grounding

- This product must be sufficiently grounded in accordance with National Electrical Code (C.E.C. in Canada) and any applicable local ordinance.
- A grounding lug is provided.

### • Auxiliary Electric Heater Kits RXBH-

Heater Kits include circuit breakers which meet UL and cUL requirements for service disconnect. See the Electric Heat Electrical Data in this specification sheet for specific Heater Kit Model numbers.

### • External Filter Base RXHF-

Model Cabinet Size	Filter Size In. [mm]	Part Number*	A	B
17	16 x 20 [406 x 508]	RXHF-17	15.70	17.5
21	20 x 20 [508 x 508]	RXHF-21	19.20	21.0
24	25 x 20 [635 x 508]	RXHF-24	22.70	25.5

\*Accommodates 1" or 2" filter

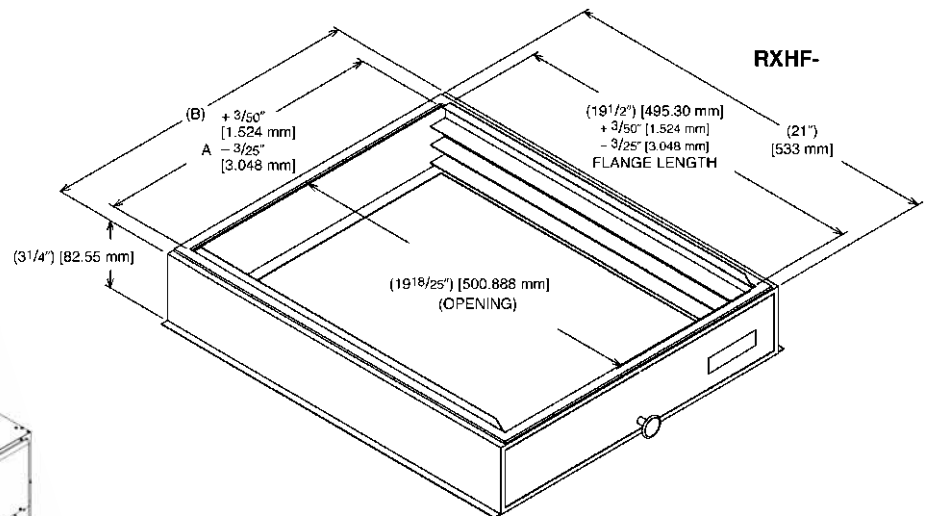

**GENERAL TERMS OF LIMITED WARRANTY\***

Ruud will furnish a replacement for any part of this product which fails in normal use and service within the applicable periods stated, in accordance with the terms of the limited warranty.

Conditional Parts (Registration Required) .....Ten (10) Years

**\*For complete details of the Limited and Conditional Warranties, including applicable terms and conditions, contact your local contractor or the Manufacturer for a copy of the product warranty certificate.**

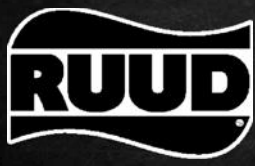

*In keeping with its policy of continuous progress and product improvement, Ruud reserves the right to make changes without notice.*

Ruud Heating, Cooling & Water Heating • P.O. Box 17010  
Fort Smith, Arkansas 72917 • [www.ruud.com](http://www.ruud.com)

Ruud Canada • 125 Edgeware Road, Unit 1  
Brampton, Ontario • L6Y 0P5

**RELY ON RUUD.™**