



## Hydronic Air Handler Powered by Tankless Technology

### RW1P/RW1T- Series

- Nominal Heating Capacities:  
40-100 kBTU [11.7-29.3 kW]



### Tankless Water Heater Models:

#### **RUTG-64DVL indoor direct vent and RUTG-64XL outdoor**

- Natural and LP models – 11,000 - 150,000 BTU max.
- 6.4 gal./min at 35° F rise max., 5.6 gal./min. at 45° F rise

#### **RUTG-84DVL indoor direct vent and RUTG-84XL outdoor**

- Natural and LP models – 11,000 - 180,000 BTU max.
- 8.4 gal./min at 35° F rise max., 6.7 gal./min. at 45° F rise

#### **RUTGH-84DVL indoor direct vent and RUTGH-84XL outdoor**

- Natural and LP models – 11,000 - 157,000 BTU max.
- 8.4 gal./min at 35° F rise max., 6.6 gal./min. at 45° F rise

#### **RUTGH-90DVL indoor direct vent and RUTGH-90XL outdoor**

- Natural and LP models – 11,000 - 180,000 BTU max.
- 9.0 gal./min at 35° F rise max., 7.5 gal./min. at 45° F rise

#### **RUTG-95DVL indoor direct vent and RUTG-95XL outdoor**

- Natural and LP models – 11,000 - 199,900 BTU max.
- 9.5 gal./min at 35° F rise max., 7.4 gal./min. at 45° F rise

#### **RUTGH-95DVL indoor direct vent and RUTGH-95XL outdoor**

- Natural and LP models – 11,000 - 199,900 BTU max.
- 9.5 gal./min at 35° F rise max., 8.4 gal./min. at 45° F rise



# TABLE OF CONTENTS

System Components .....	3
Model Features & Model Number Identification .....	4
General Data .....	5
Dimensional Data .....	6
Airflow Performance Data .....	7-8
Water Heater Performance Data .....	9
Tankless Water Heater-Mid Efficiency Tankless Series .....	10-11
Tankless Water Heater-Condensing Tankless Series .....	12-13
Accessories .....	14
Typical Piping .....	15
Limited Warranty .....	16

## Home Heating & Water Heating Powered by Tankless Technology

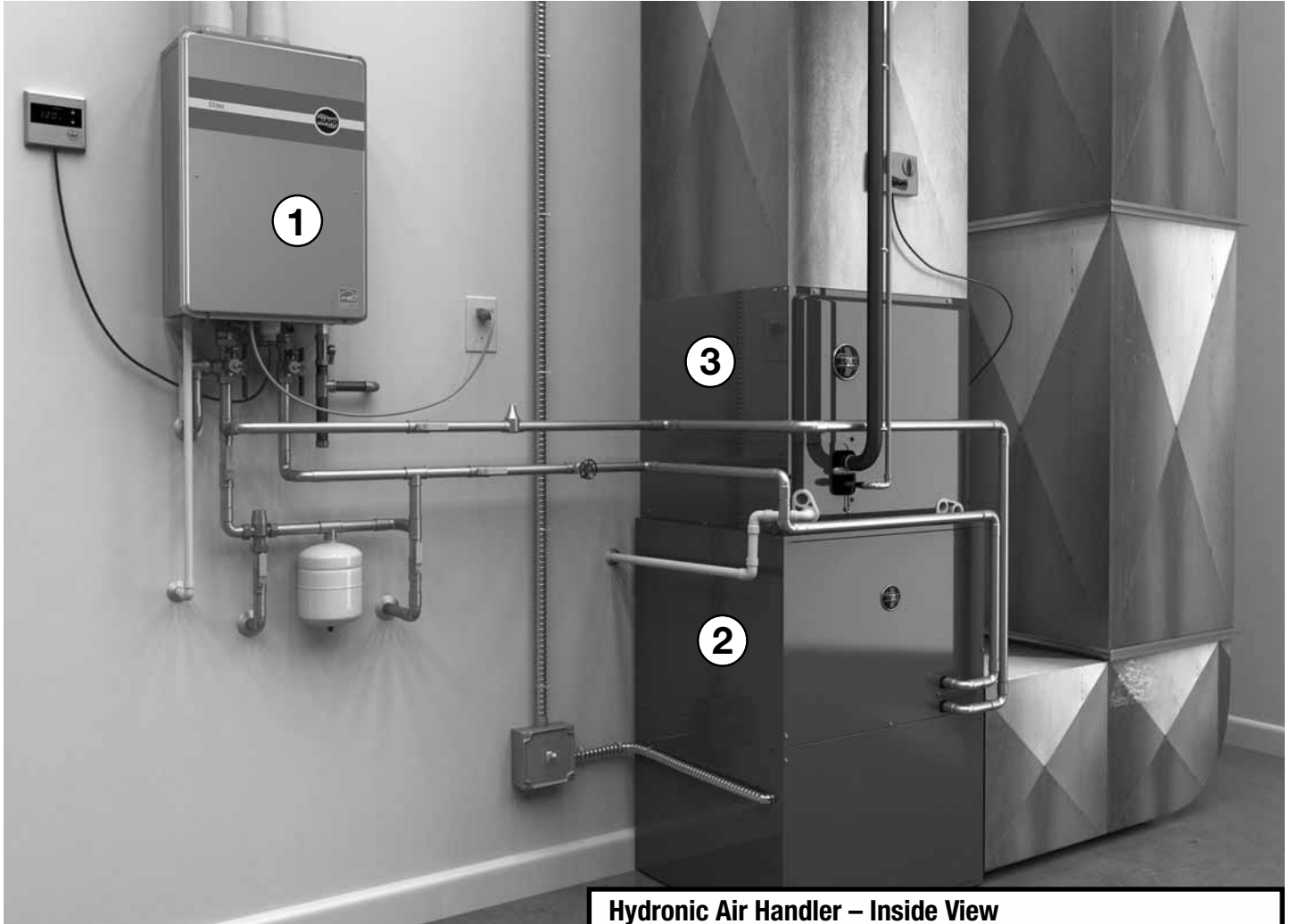

### System Components

#### ① Tankless Water Heater

The Ruud tankless water heater serves two purposes in the hydronic system: it provides continuous hot water for use throughout the home. When a call for heat is made, the tankless water heater also acts as the heat-source for air handler, providing both hot water and heating for the home simultaneously.

#### ② Hydronic Air Handler

The hydronic air handler features a hydronic heating coil in place of either electric heating elements or gas-fired heat exchangers. When in heating mode, the hydro pump circulates hot water between the tankless water heater and the hydronic coil.

#### ③ Cooling Coil

In cooling mode, the cooling coil operates the same as any other Ruud heating and cooling system.

### Hydronic Air Handler – Inside View

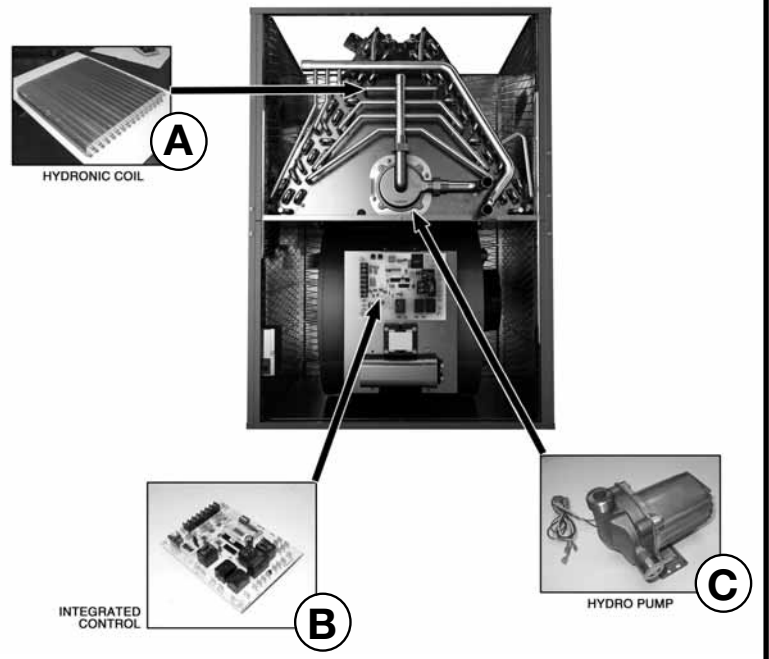

## Model Features

### Features of the Hydronic Air Handler

- Low profile 34-inch design is lighter, easier to handle and leaves room for optional accessories
- Left or right side electric connections
- Integrated control board features diagnostics, manages all operational functions and provides hookups for humidifier and electronic air cleaner
- An insulated blower compartment makes it one of the quietest hydronic air handlers on the market today
- Pre-paint galvanized steel cabinet
- Molded permanent filter(s)
- Transformer and control fuse protection
- Solid bottom is standard
- A variety of cooling coils and plenums designed to use with the Hydronic Air Handler are available as optional accessories for air conditioning models
- Stainless steel water pump
- Field convertible for vertical downflow, horizontal left hand, or right hand air supply.

### Features of the Tankless Water Heater

- **Industry best!** Minimum flow rate of .26 GPM, minimum activation flow rate of .40 GPM
- ENERGY STAR® rated models available
- Next generation burner technology
- UMC-117 remote control and 10 ft. of thermostat wire is included
- EZ-Link™ cable available for high demand applications to connect two tankless units to operate as one
- High-altitude capability – up to 9,840 ft. elevation above sea level (no chip required)
- Intelligent electronic controls designed to increase energy efficiency and safety
- Self Diagnostic System

## Hydronic Air Handler Model Identification

<u>R</u>	<u>W</u>	<u>1</u>	<u>T</u>	<u>04</u>	<u>A</u>	<u>24</u>	<u>14</u>	<u>N</u>	<u>A</u>	<u>A</u>	<u>*</u>
Brand	Product Category	Stages of Airflow	Motor Type	Nominal Capacity BTU/HR [kW]	Major Series	Max Cooling Airflow Tonnage	Width	Controls	Voltage	Minor Series**	Option Code
R = Ruud	W = Hydronic	1 = Single Stage	P = PSC T = Constant Torque	04 = 40,000 [11.7 kW] 06 = 60,000 [17.6 kW] 08 = 80,000 [23.5 kW] 10 = 100,000 [29.0 kW]	A = First	24 = Up to 2 Ton 36 = Up to 3 Ton 48 = 2.5 to 4 Ton 60 = 3 to 5 Ton	14 = 14" 17 = 17.5" 21 = 21" 24 = 24.5"	C-Communicating N-Non-comm	A - 1ph, 115/60	A = 1st Design	*TBD

[ ] Designates Metric Conversions

**IMPORTANT: BEFORE PURCHASING THIS APPLIANCE, READ IMPORTANT ENERGY COST AND EFFICIENCY INFORMATION AVAILABLE FROM YOUR RETAILER.**

**General Data Eco Tech™ (ECM) Models  
U.S. and Canadian Models**

Hydronic Air Handler Electrical Physical Specifications - Eco Tech Models				
MODEL NUMBERS	RW1P04A2414NAA	RW1P06A3617NAA	RW1P08A4821NAA	RW1P10A6024NAA
Nominal Heating Capacity BTU/hr [kw]	40000 [11.7]	60000 [17.6]	80000 [23.4]	100000 [29.3]
Air Side Temperature Rise* °F [°C]	32-53 [17.6-29.2]	24-43 [13.2-23.7]	25-49 [13.8-27.0]	25-46 [13.8-25.3]
Rated Heating CFM [L/s]	800 [378]	1200 [566]	1625 [767]	1800 [850]
Cooling Range CFM [L/s]	600-800 [283-556]	800-1200 [283-612]	900-1625 [424-641]	1050-1850 [472-873]
Power Supply (V - HZ - PH)	115 - 60 -1			
Minimum Circuit Ampacity - Amps	5	10	10	11
Max Rating of Over Current Protective Device - Amps	15	15	15	15
Maximum Fuse or Circuit Breaker Size - Amps	15	15	15	15
Motor HP [W]	1/5 [93]	1/2 [373]	1/2 [373]	3/4 [559]
Blower (D x W) in [mm]	10 x 6 [254 x 152]	10 x 8 [254 x 203]	10 x 10 [254 x 254]	11 x 11 [279 x 279]
Blower Motor Type	PSC			
Pump Type	Wet Rotor			
Pump Power Supply (V - HZ - PH)	115 - 60 -1			
Pump Motor RLA/LRA - Amps	1.8			
Pump HP [W]	1/8 [.86]			
Pump Maximum Working Pressure psi [kPa]	125 [861]			
Max Working Temperature °F [°C]	160 [71]			
Water Connection Type	Copper Studs			
Inlet Water Connection Diameter in [mm]	3/4 [19]			
Out Water Connection Diameter in [mm]	3/4 [19]			
Shipping Weight LBS [kg]	91 [41]	100 [45]	122 [55]	129 [58]

Hydronic Air Handler Electrical Physical Specifications - Eco Tech Models				
MODEL NUMBERS	RW1T04A2414NAA	RW1T06A3617NAA	RW1T08A4821NAA	RW1T10A6024NAA
Nominal Heating Capacity BTU/hr [kw]	40000 [11.7]	60000 [17.6]	80000 [23.4]	100000 [29.3]
Air Side Temperature Rise* °F [°C]	32-53 [0-11.6]	24-43 [-4.4-6.1]	25-49 [-3.9-9.4]	25-46 [-3.9-7.8]
Rated Heating CFM [L/s]	800 [378]	1200 [566]	1625 [767]	1800 [850]
Cooling Range CFM [L/s]	600-800 [283-556]	800-1200 [283-612]	1000-1625 [472-775]	1200-1800 [612-804]
Power Supply (V - HZ - PH)	115 - 60 -1			
Minimum Circuit Ampacity - Amps	8	10	12.9	12.9
Max Rating of Over Current Protective Device - Amps	11.7	18	23.2	23.2
Maximum Fuse or Circuit Breaker Size - Amps	10	15	20	20
Motor HP [W]	1/3 [248]	1/2 [373]	3/4 [559]	3/4 [559]
Blower (D x W) in [mm]	10 x 6 [254 x 152]	10 x 8 [254 x 203]	10 x 10 [254 x 254]	11 x 11 [279 x 279]
Blower Motor Type	EcoTech / ECM Type			
Pump Type	Wet Rotor			
Pump Power Supply (V - HZ - PH)	115 - 60 -1			
Pump Motor RLA/LRA - Amps	1.8			
Pump HP [W]	1/8 [.86]			
Pump Maximum Working Pressure psi [kPa]	125 [861]			
Max Working Temperature °F [°C]	160 [71]			
Water Connection Type	Copper Studs			
Inlet Water Connection Diameter in [mm]	3/4 [19]			
Out Water Connection Diameter in [mm]	3/4 [19]			
Shipping Weight LBS [kg]	91 [41]	100 [45]	122 [55]	129 [58]

[ ] Designates Metric Conversions

## Hydronic Air Handler Dimensions and Specifications

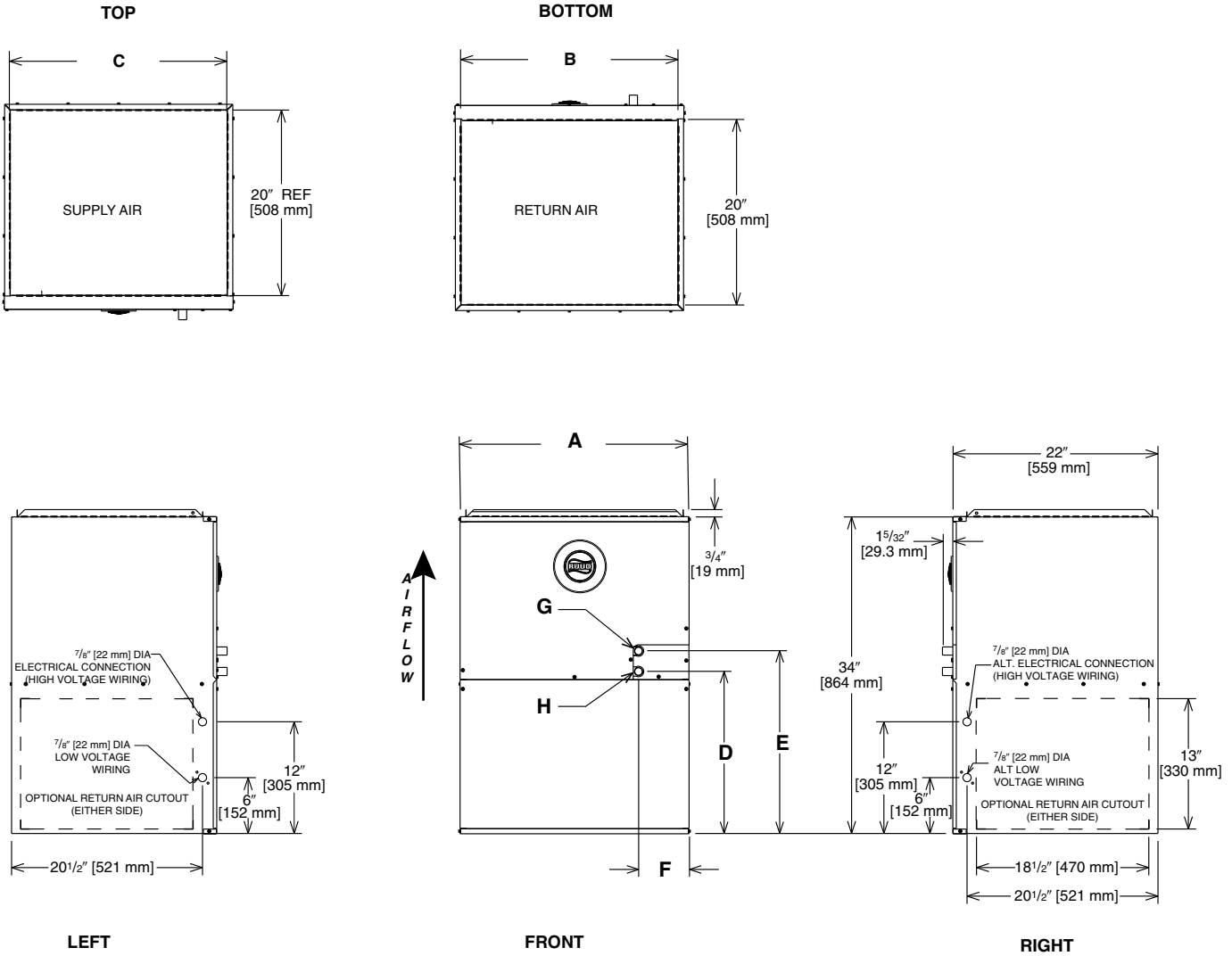

ST-A1242-03-X0

### Dimensions and Clearance to Combustible Material (inches) [mm]

MODEL	A	B	C	D	E	F
RW1*04A2414	14 [356]	13 [330]	13 [330]	16-13/16 [427]	19 [483]	3-3/8 [86]
RW1*06A3617	17-1/2 [445]	16-1/2 [419]	16-1/2 [419]	16-13/16 [427]	19 [483]	4/5/8 [117]
RW1*08A4821	21 [533]	20 [508]	20 [508]	16-13/16 [427]	19 [483]	4-7/16 [113]
RW1*10A6024	24-1/2 [622]	23-1/2 [597]	23-1/2 [597]	17-7/16 [443]	19-5/8 [498]	5-7/16 [138]

\*A service clearance of at least 24 inches [634mm] is recommended in front of all air handlers.

[ ] Designates Metric Conversions

## Hydronic Air Handler Airflow Performance—PSC Models

HYDRONIC AIR HANDLER AIR FLOW PERFORMANCE — PSC MODELS														
Model	Blower Size in (mm)	Motor HP [Watt]	Blower Speed	CFM [L/s] Air Delivery External Static Pressure Inches Water Column [kPa]										
				0.1 [.02]	0.2 [.05]	0.3 [.07]	0.4 [.10]	0.5 [.12]	0.6 [.15]	0.7 [.17]	0.8 [.19]	0.9 [.22]		
RW1P 04A2414NAA	10 x 6 [254 x 152]	1/5 [93]	Low	642 [339]	612 [322]	591 [311]	524 [273]	—	—	—	—	—	—	
			Med-low	711 [371]	684 [362]	655 [346]	624 [329]	578 [303]	526 [274]	—	—	—	—	
			Med-high	890 [477]	853 [456]	821 [438]	786 [419]	744 [396]	694 [368]	633 [334]	549 [287]	—	—	—
			High	950 [510]	917 [492]	880 [471]	843 [451]	803 [428]	752 [400]	689 [365]	690 [366]	604 [318]	—	—
RW1P 06A3617NAA	10 x 8 [254 x 203]	1/2 [373]	Low	900 [482]	882 [472]	865 [463]	843 [451]	806 [430]	759 [404]	687 [364]	617 [325]	—	—	
			Med-low	1135 [613]	1101 [594]	1073 [578]	1050 [566]	1012 [544]	960 [516]	889 [476]	801 [427]	700 [371]	—	—
			Med-high	1260 [682]	1231 [666]	1199 [648]	1154 [623]	1113 [601]	1060 [571]	978 [526]	895 [479]	767 [408]	—	—
			High	1397 [758]	1363 [739]	1314 [712]	1268 [687]	1209 [654]	1148 [620]	1077 [581]	980 [527]	829 [443]	—	—
RW1P 08A4821NAA	10 x 10 [254 x 254]	1/2 [373]	Low	947 [508]	943 [506]	940 [504]	926 [497]	897 [481]	857 [458]	784 [418]	711 [377]	—	—	
			Med-low	1200 [649]	1193 [645]	1183 [639]	1163 [628]	1137 [614]	1084 [584]	1025 [552]	917 [492]	769 [409]	—	—
			Med-high	1493 [812]	1481 [805]	1452 [789]	1411 [766]	1365 [741]	1220 [660]	1124 [607]	957 [514]	—	—	—
			High	1865 [1018]	1810 [988]	1737 [947]	1671 [911]	1608 [876]	1533 [834]	1457 [792]	1292 [700]	1135 [613]	—	—
RW1P 10A6024NAA	11 x 11 [279 x 279]	3/4 [559]	Low	904 [484]	875 [468]	845 [452]	798 [426]	735 [391]	688 [364]	643 [339]	593 [312]	—	—	
			Med-low	1189 [643]	1165 [629]	1114 [601]	1092 [589]	1057 [569]	1005 [541]	947 [508]	879 [471]	821 [438]	—	—
			Med-high	1326 [719]	1304 [707]	1286 [697]	1266 [686]	1244 [673]	1217 [658]	1189 [643]	1140 [616]	1060 [571]	—	—
			High	1970 [1077]	1951 [1066]	1937 [1058]	1926 [1052]	1895 [1035]	1865 [1018]	1759 [959]	1673 [912]	1624 [884]	—	—

Blower performance measured without filter in place.

[ ] Designates Metric Conversions

# Hydronic Air Handler Airflow Performance—Eco Tech™ (ECM) Models

HYDRONIC AIR HANDLER AIR FLOW PERFORMANCE — ECHO TECH MODELS															
Model	Blower Size in [mm]	Motor HP [Watt]	Blower Speed	CFM [L/s] Air Delivery External Static Pressure Inches Water Column [kPa]											
				0.1 [0.02]	0.2 [0.05]	0.3 [0.07]	0.4 [0.10]	0.5 [0.12]	0.6 [0.15]	0.7 [0.17]	0.8 [0.19]	0.9 [0.22]			
RW1T 04A2414NAA	10 x 6 [254 x 152]	1/3 [248]	Low	686 [324]	634 [299]	582 [275]	530 [250]	—	—	—	—	—	—	—	—
			Med-low	723 [341]	688 [325]	617 [291]	567 [268]	512 [242]	459 [217]	—	—	—	—	—	—
			Med	748 [353]	697 [329]	648 [306]	597 [282]	548 [259]	491 [232]	445 [210]	—	—	—	—	—
			Med-high	922 [435]	885 [418]	849 [401]	811 [383]	775 [366]	733 [346]	695 [328]	644 [304]	628 [296]	—	—	—
			High	940 [444]	917 [433]	875 [413]	838 [395]	799 [377]	760 [359]	716 [338]	673 [318]	628 [296]	—	—	—
RW1T 06A3617NAA	10 x 8 [254 x 203]	1/2 [373]	Low	646 [305]	582 [275]	517 [244]	436 [206]	—	—	—	—	—	—	—	—
			Med-low	984 [464]	937 [442]	894 [422]	846 [399]	798 [377]	757 [357]	710 [335]	—	—	—	—	
			Med	1037 [489]	995 [470]	953 [450]	910 [429]	868 [410]	821 [387]	781 [369]	737 [348]	—	—	—	
			Med-high	1161 [548]	1020 [481]	1078 [509]	1040 [491]	999 [471]	963 [454]	920 [434]	873 [412]	753 [355]	—	—	
			High	1397 [659]	1354 [639]	1321 [623]	1279 [604]	1238 [584]	1193 [563]	1157 [546]	1068 [504]	956 [451]	—	—	
RW1T 08A4821NAA	10 x 10 [254 x 254]	3/4 [559]	Low	815 [385]	765 [361]	715 [337]	665 [314]	614 [290]	568 [263]	514 [243]	—	—	—	—	
			Med-low	1284 [606]	1233 [582]	1178 [556]	1129 [533]	1070 [505]	999 [471]	927 [437]	876 [413]	823 [388]	—	—	
			Med	1419 [670]	1373 [648]	1323 [624]	1282 [605]	1228 [580]	1180 [557]	1129 [533]	1054 [497]	981 [463]	—	—	
			Med-high	1485 [701]	1452 [685]	1418 [669]	1386 [654]	1346 [635]	1313 [620]	1272 [600]	1222 [577]	1195 [564]	—	—	
			High	1745 [824]	1722 [813]	1692 [799]	1664 [785]	1630 [769]	1599 [755]	1566 [739]	1504 [710]	1356 [640]	—	—	
RW1T 10A6024NAA	11 x 11 [279 x 279]	3/4 [559]	Low	1044 [493]	953 [450]	867 [409]	767 [362]	667 [315]	579 [273]	501 [236]	—	—	—		
			Med-low	1010 [477]	970 [458]	936 [442]	902 [426]	867 [409]	832 [393]	798 [377]	766 [362]	725 [342]	—	—	
			Med	1247 [589]	1183 [558]	1121 [529]	1064 [502]	999 [471]	933 [440]	864 [408]	797 [376]	735 [347]	—	—	
			Med-high	1834 [866]	1768 [834]	1697 [801]	1639 [774]	1585 [748]	1539 [726]	1478 [698]	1427 [673]	1370 [647]	—	—	
			High	2008 [948]	1956 [923]	1905 [899]	1844 [870]	1802 [850]	1750 [826]	1698 [801]	1655 [781]	1604 [757]	—	—	

Blower performance measured without filter in place.

[ ] Designates Metric Conversions



## Hydronic Air Handler with Tankless Water Heater Performance

AIR HANDLER MODEL	WATER TEMPERATURE			WATER FLOW RATE (GPM)	BLOWER SPEED	EXTERNAL STATIC PRESSURE (IN. W.C.)	AIR FLOW (CFM) [L/s]	AIR TEMPERATURE			HEAT CAPACITY (BTU/HR) [kW]
	INLET	OUTLET	DELTA					INLET	OUTLET	DELTA	
	(°F) [°C]			(°F) [°C]							
RW1*04A	120 [49]	109 [43]	11 [6]	5.0	High	0.54	800 [378]	68 [20]	102 [39]	31 [29]	26914 [8]
	130 [54]	116 [47]	14 [7]	4.6					108 [42.1]	36 [26]	31488 [9]
	140 [60]	122 [50]	18 [10]	4.0					113 [44.7]	41 [23]	35628 [10]
	150 [66]	129 [54]	21 [12]	3.8					119 [48.3]	47 [20]	40593 [12]
	160 [71]	132 [56]	28 [15]	3.3					120 [48.9]	53 [19]	45454 [13]
RW1*06A	120 [49]	96 [36]	24 [13]	4.0	High	0.59	1200 [566]	68 [20]	104 [40.2]	36 [28]	47040 [14]
	130 [54]	101 [38]	29 [16]	3.8					110 [43.3]	42 [25]	54300 [16]
	140 [60]	105 [41]	35 [21]	3.3					112 [44.7]	44 [23]	57598 [17]
	150 [66]	115 [46]	35 [20]	3.4					114 [45.4]	46 [23]	59348 [17]
	160 [71]	121 [49]	39 [22]	3.3					118 [47.6]	50 [20]	64398 [19]
RW1*08A	120 [49]	100 [38]	10 [11]	4.8	High	0.5	1625 [767]	68 [20]	95 [35.1]	27 [33]	47766 [14]
	130 [54]	103 [39]	27 [15]	4.2					100 [37.6]	32 [30]	55703 [16]
	140 [60]	105 [41]	35 [21]	3.6					104 [39.7]	36 [28]	62341 [18]
	150 [66]	108 [42]	42 [24]	3.5					110 [43.5]	42 [25]	74147 [22]
	160 [71]	106 [41]	54 [30]	3.0					114 [45.6]	46 [22]	80997 [24]
RW1*10A	120 [49]	93 [34]	27 [15]	4.6	High	0.5	1800 [850]	68 [20]	100 [37.8]	32 [30]	62308 [18]
	130 [54]	98 [37]	32 [17]	4.2					103 [39.3]	35 [29]	67635 [20]
	140 [60]	101 [38]	39 [22]	3.6					104 [40]	36 [28]	69936 [20]
	150 [66]	103 [40]	47 [26]	3.6					111 [44]	43 [24]	84130 [25]
	160 [71]	101 [38]	59 [33]	3.3					118 [47.9]	50 [20]	97514 [29]

CFM = Cubic Feet Per Minute

ESP = External Static Pressure

\*Recommended Operating Point

Inlet Air at 68°F [20°C]

Capacities are based on a piping arrangement with a total equivalent length of 100 ft [30m].

Entering water temperatures must not exceed 160°F [71°C]

[ ] Designates Metric Conversions

## Ruud Ultra™ RUTGH is a series of high-efficiency condensing tankless gas water heaters designed for continuous hot water

### Efficiency

- Up to .94 EF with stainless steel condensing heat exchanger
- Intelligent electronic controls designed to increase energy efficiency and safety
- Third party efficiency listed by AHRI

### Performance

- Industry First! 0.26 GPM minimum flow rate, 0.40 GPM minimum activation flow rate
- SCAQMD rule 1146.2 compliant
- RUTGH-95 for 3 bathroom homes\*– 9.5 gal./min. at 35°F rise max., 8.4 gal./min. at 45°F rise
- RUTGH-90 for 2-3 bathroom homes\*– 9.0 gal./min. at 35°F rise max., 7.5 gal./min. at 45°F rise
- RUTGH-84 for 2-3 bathroom homes\*–8.4 gal./min. at 35°F rise max., 6.6 gal./min. at 45°F rise

### Compact Size

- Compact space-saving design – about the size of a medicine cabinet

### Self-Diagnostic System

- Self-diagnostic system for easy installation and service.
- Digital display shows temperature setting and maintenance codes

### Technology

- Two-pipe direct vent system designed for PVC pipe (up to 38 ft. of 3" PVC pipe or 5 ft. of 2" PVC pipe). See instructions for details
- Hot-start programming helps minimize fluctuation in water temperature, referred to as “cold water sandwich effect,” during periods of frequent on/off operation
- Built-in electric blower
- Exclusive! Guardian OFW™ overheat film wrap
- EZ-Link™ cable available for higher demand applications to connect two tankless units to operate as one
- Manifold up to six units with an optional MIC-6 manifold control board
- Manifold up to 20 units with the optional MIC-185 plus the MICS-180 manifold control assembly

### High-Altitude Compliant

- High-altitude capability – up to 9,840 ft. elevation above sea level

### Plus...

- Digital remote control and 10 ft. of thermostat wire included
- Supplied with a 120-volt power cord (indoor models only)
- Freeze protection to -30°F
- Required manual gas isolation valve included
- EZ- Spec™ Sizing Software – advanced online tool that takes the guess work out of sizing tankless applications – available at [www.ruud.com/tankless](http://www.ruud.com/tankless)

### Warranty

- 12-Year heat exchanger – residential, 5-year heat exchanger – commercial, 5-year parts and 1-year labor
- See Warranty Certificate for complete information

### Commercial Applications

The RUTGH Condensing Tankless Series can be upgraded for high-temperature commercial use.

- Temperature range is 85°F to 185°F

#### RUTGH-95 Upgrade Kits

RTG20240A for RUTGH-95DVLN  
RTG20240B for RUTGH-95DVLP  
RTG20240C for RUTGH-95XLN  
RTG20240D for RUTGH-95XLP

#### RUTGH-90 Upgrade Kits

RTG20244A for RUTGH-90DVLN  
RTG20244B for RUTGH-90DVLP  
RTG20244C for RUTGH-90XLN  
RTG20244D for RUTGH-90XLP

#### RUTGH-84 Upgrade Kits

RTG20241A for RUTGH-84DVLN  
RTG20241B for RUTGH-84DVLP  
RTG20241C for RUTGH-84XLN  
RTG20241D for RUTGH-84XLP

Note: These upgrade kits are not compatible with previous models. See the Tankless Parts and Accessories Catalog for a complete listing.

\* Based on simultaneous showers using 2.5 gallons per minute. Flow rates vary depending on temperature of cold water supply.



**RUTGH-DVL**  
Indoor Direct Vent Model  
11,000-199,900 Btu/h  
Natural and LP Gas



**RUTGH-XL**  
Outdoor Model  
11,000-199,900 Btu/h  
Natural and LP Gas



LEED Points = 2

## Ruud Ultra™ Specifications

DESCRIPTION			FEATURES						ROUGHING IN DIMENSIONS (SHOWN IN INCHES)						ENERGY INFO.		
MODEL NUMBER	GAS INPUT BTU/H	TYPE	TEMP. RANGE	MIN. FLOW/ACTIVATION GPM	GPM @ 77° RISE MAX.	GPM @ 45° RISE MAX.	MAX. GPM	CONNECTION		HEIGHT	WIDTH	DEPTH	VENT DIAM.	SHIP. WEIGHT (LBS.)	ENERGY FACTOR	RECOVERY EFFICIENCY	EST. YEARLY ENERGY COST NAT/LP
								WATER	GAS								
<b>Ruud Ultra™ RUTGH-95 for 3 Bathroom Homes</b>																	
RUTGH-95DVLN	11,000-199,900	Indoor Direct Vent	85° to 140° F	0.26/0.40	4.9	8.4	9.5	3/4	3/4	27-1/2	18-1/2	9-3/4	2" or 3" PVC 2-Pipe	82	.94	94%	\$174/421
RUTGH-95XLN	11,000-199,900	Outdoor	85° to 140° F	0.26/0.40	4.9	8.4	9.5	3/4	3/4	27-1/2	18-1/2	9-3/4	N/A	82	.94	94%	\$174/421
<b>Ruud Ultra™ RUTGH-90 for 2-3 Bathroom Homes</b>																	
RUTGH-90DVLN	11,000-180,000	Indoor Direct Vent	85° to 140° F	0.26/0.40	4.4	7.5	9.0	3/4	3/4	27-1/2	18-1/2	9-3/4	2" or 3" PVC 2-Pipe	82	.93	93%	\$176/425
RUTGH-90XLN	11,000-180,000	Outdoor	85° to 140° F	0.26/0.40	4.4	7.5	9.0	3/4	3/4	27-1/2	18-1/2	9-3/4	N/A	82	.93	93%	\$176/425
<b>Ruud Ultra™ RUTGH-84 for 2-3 Bathroom Homes</b>																	
RUTGH-84DVLN	11,000-157,000	Indoor Direct Vent	85° to 140° F	0.26/0.40	3.9	6.6	8.4	3/4	3/4	27-1/2	18-1/2	9-3/4	2" or 3" PVC 2-Pipe	82	.92	92%	\$178/430
RUTGH-84XLN	11,000-157,000	Outdoor	85° to 140° F	0.26/0.40	3.9	6.6	8.4	3/4	3/4	27-1/2	18-1/2	9-3/4	N/A	82	.92	92%	\$178/430

Estimated energy cost based on a national average fuel cost of \$1.09/therm for natural gas and \$2.41/gallon for LP. Energy factor determined by the U.S. Department of Energy (DOE) test procedures.

All models are available in Natural Gas and Propane (LP). For Propane replace the N with P when ordering.

- SCAQMD 1146.2 compliant.
- Factory set maximum temperature is 120° F. See Use and Care Manual for setting.
- Consult factory for information on sizing the application.
- Add a "C" to the model number when ordering Canadian models. Outdoor models are only for seasonal use in Canada. Please contact Ruud Canada Ltd. for details.

Vent Termination Kits are required for Direct Vent models. Contact your distributor for details.

Proper gas pressure must be ensured to supply tankless gas water heaters – up to 199,900 Btu/h for RUTGH-95 models, up to 180,000 Btu/h for RUTGH-90 models, up to 157,000 Btu/h for RUTGH-84 models. (Consult your gas supplier)

Model Number	Temperature Rise (° F)								
	35°	45°	50°	60°	70°	77°	80°	90°	100°
RUTGH-95 Water Flow (GPM)	9.5	8.4	7.6	6.3	5.4	4.9	4.7	4.2	3.8
RUTGH-90 Water Flow (GPM)	9.0	7.5	6.8	5.6	4.8	4.4	4.2	3.8	3.4
RUTGH-84 Water Flow (GPM)	8.4	6.6	6.0	5.0	4.3	3.9	3.7	3.3	3.0

Above estimates are for sizing purposes only.

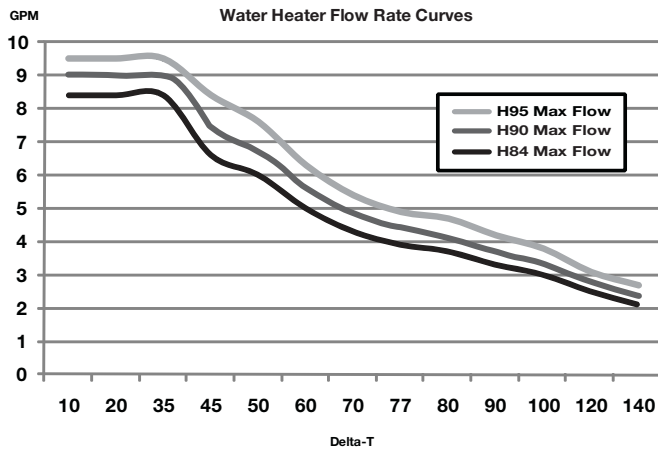

### Maximum Vent Length (intake/outlet):

Number of 90° Elbows	Maximum Length of 2" Straight Pipe	Maximum Length of 3" Straight Pipe
0 or 1	5.0 ft. (1.5 m)	38.0 ft. (11.6 m)
2	3.5 ft. (1.0 m)	36.5 ft. (11.1 m)
3	2.0 ft. (0.6 m)	35.0 ft. (10.6 m)
4	Not Available	33.5 ft. (10.2 m)
5	Not Available	32.0 ft. (9.8 m)
6	Not Available	30.5 ft. (9.3 m)

(ULC-S636 pipe must be used for Canada.)

### Indoor Direct Vent

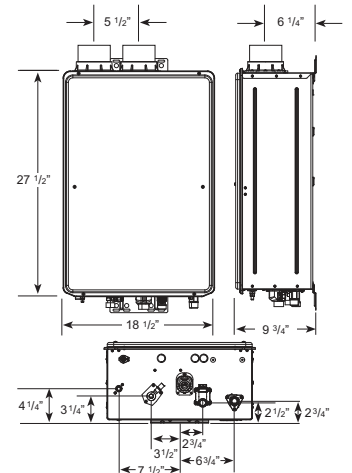

### Outdoor

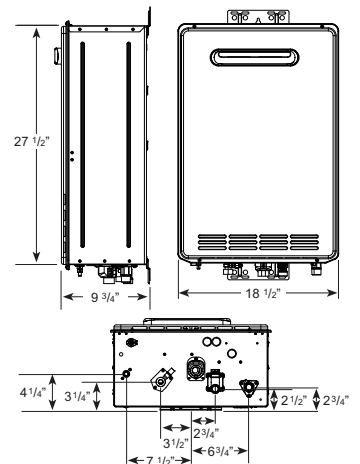

## Parts and Accessories

Venting & terminations – 2" or 3" PVC, recess boxes, pipe covers, extra remote controls, EZ-Link™ cable, manifolds and cables, service valve kits, service parts and flush kits.

For more information on Tankless parts and accessories, see the Parts and Accessories Catalog or call 866-720-2076.

## Ruud RUTG is a series of ultra low NOx, mid-efficiency tankless gas water heaters designed for continuous hot water

### Efficiency

- .82 EF with all-copper heat exchanger
- Intelligent electronic controls designed to increase energy efficiency and safety
- Third party efficiency listed by AHRI

### Performance

- Industry First! 0.26 GPM minimum flow rate, 0.40 GPM minimum activation flow rate
- RUTG-95 for 3 bathroom homes\*– 9.5 gal./min. at 35°F rise max., 7.4 gal./min. at 45°F rise
- RUTG-84 for 2-3 bathroom homes\*– 8.4 gal./min. at 35°F rise max., 6.7 gal./min. at 45°F rise
- RUTG-64 for 1-2 bathroom homes\*– 6.4 gal./min. at 35°F rise max., 5.6 gal./min. at 45°F rise

### Self-Diagnostic System

- Self-diagnostic system for easy installation and service
- Digital display shows temperature setting and maintenance codes

### Technology

- 3"/5" concentric vent system with Integrated condensate collector
- Hot-start programming helps minimize fluctuation in water temperature, referred to as "cold water sandwich", during periods of frequent on/off operation
- Connects to Metal Fab. Inc., 3"/5" concentric venting without an adapter
- Built-in electric blower
- Exclusive! Guardian OFW™ overheat film wrap
- EZ-Link™ cable available for higher demand applications to connect two tankless units to operate as one
- Manifold up to six units with an optional MIC-6 manifold control board
- Manifold up to 20 units with the optional MIC-185 plus the MICS-180 manifold control assembly

### Low Emissions

- Environmentally friendly ultra low NOx burner meets SCAQMD rule 1146.2 requirements

### High Altitude Compliant

- High-altitude capability – up to 9,840 ft. elevation above sea level

### Plus...

- Digital remote control and 10 ft. of thermostat wire included
- Supplied with a 120-volt power cord (indoor models only)
- Freeze protection to -30°F
- Required manual gas isolation valve included
- EZ- Spec™ Sizing Software – advanced online tool that takes the guess work out of sizing tankless applications – available at [www.ruud.com/tankless](http://www.ruud.com/tankless)

### Warranty

- 12-Year heat exchanger – residential, 5-year heat exchanger – commercial, 5-year parts and 1-year labor
- See Warranty Certificate for complete information

### Commercial Applications

The RUTG Tankless Series can be upgraded for high-temperature commercial and hydronic use.

- Temperature range is 85°F to 185°F

### RUTG-95 Upgrade Kits

RTG20236A for RUTG-95DVLN  
RTG20236B for RUTG-95DVLP  
RTG20236C for RUTG-95XLN  
RTG20236D for RUTG-95XLP

### RUTG-84 Upgrade Kits

RTG20237A for RUTG-84DVLN  
RTG20237B for RUTG-84DVLP  
RTG20237C for RUTG-84XLN  
RTG20237D for RUTG-84XLP

Note: These upgrade kits are not compatible with previous models. See the latest Tankless Parts and Accessories Catalog for a complete listing.

\* Based on simultaneous showers using 2.5 gallons per minute. Flow rates vary depending on temperature of cold water supply.



### RUTG-DVL

Indoor Direct Vent Model  
11,000-199,900 Btu/h  
Natural and LP Gas



### RUTG-XL

Outdoor Model  
11,000-199,900 Btu/h  
Natural and LP Gas



LEED Points = 2

## Specifications

DESCRIPTION			FEATURES						ROUGHING IN DIMENSIONS (SHOWN IN INCHES)						ENERGY INFO.		
MODEL NUMBER	GAS INPUT BTU/H	TYPE	TEMP. RANGE	MIN. FLOW/ACTIVATION GPM	GPM @ 77° RISE MAX.	GPM @ 45° RISE MAX.	MAX. GPM	CONNECTION		HEIGHT	WIDTH	DEPTH	VENT DIAM.	SHIP. WEIGHT (LBS.)	ENERGY FACTOR	RECOVERY EFFICIENCY	D.O.E. ANN. OP. COST NAT/LP
								WATER	GAS								
<b>RUTG-95 ULTRA LOW NO<sub>x</sub> SERIES FOR 3 BATHROOM HOMES</b>																	
RUTG-95DVLN	11,000-199,900	Indoor Direct Vent	85° to 140° F*	0.26/0.40	4.3	7.4	9.5	3/4	3/4	25-5/8	13-7/8	9-7/8	3 by 5 CONCENTRIC	54	.82	84%	\$199/482
RUTG-95XLN	11,000-199,900	Outdoor	85° to 140° F*	0.26/0.40	4.3	7.4	9.5	3/4	3/4	23-5/8	13-7/8	8-7/8	N/A	54	.82	83%	\$199/482
<b>RUTG-84 ULTRA LOW NO<sub>x</sub> SERIES FOR 2-3 BATHROOM HOMES</b>																	
RUTG-84DVLN	11,000-180,000	Indoor Direct Vent	85° to 140° F	0.26/0.40	3.9	6.7	8.4	3/4	3/4	25-5/8	13-7/8	9-7/8	3 by 5 CONCENTRIC	54	.82	84%	\$199/482
RUTG-84XLN	11,000-180,000	Outdoor	85° to 140° F	0.26/0.40	3.9	6.7	8.4	3/4	3/4	23-5/8	13-7/8	8-7/8	N/A	54	.82	83%	\$199/482
<b>RUTG-64 ULTRA LOW NO<sub>x</sub> SERIES FOR 1-2 BATHROOM HOMES</b>																	
RUTG-64DVLN	11,000 - 150,000	Indoor Direct Vent	85° to 140° F	0.26/0.40	3.3	5.6	6.4	3/4	3/4	25-5/8	13-7/8	9-7/8	3 by 5 CONCENTRIC	54	.82	84%	\$199/482
RUTG-64XLN	11,000 - 150,000	Outdoor	85° to 140° F	0.26/0.40	3.3	5.6	6.4	3/4	3/4	23-5/8	13-7/8	8-7/8	N/A	54	.82	83%	\$199/482

Energy Factor and Average Annual Operating Costs based on 2013 D.O.E. (Department of Energy) test procedures. D.O.E. national average fuel rate natural gas \$1.09/therm; LP \$2.41/gallon.

All models are available in Natural Gas and Propane (LP). For Propane replace the N with P when ordering.

• SCQAMD rule 1146.2 compliant.

• Factory set maximum temperature is 120° F. See Use and Care Manual for setting.

• Consult factory for information on sizing the application.

• Add a "C" to the model number when ordering Canadian models. Outdoor models are only for seasonal use in Canada. Please contact Ruud Canada Ltd. for details.

Vent Termination Kits are required for Direct Vent models. Contact your distributor for details.

Proper gas pressure must be ensured to supply tankless gas water heaters – up to 199,900 Btu/h for RUTG-95 models, up to 180,000 Btu/h for RUTG-84 models and up to 150,000 Btu/h for RUTG-64 models. (Consult your gas supplier)

### Indoor Direct Vent

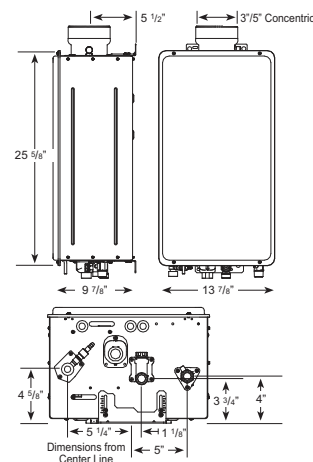

### Outdoor

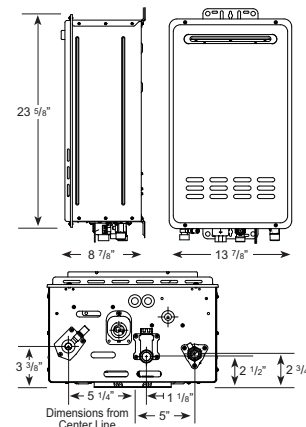

### Temperature Rise (° F)

Model Number	35°	45°	50°	60°	70°	77°	80°	90°	100°
RUTG-95 Water Flow (GPM)	9.5	7.4	6.6	5.5	4.7	4.3	4.1	3.7	3.3
RUTG-84 Water Flow (GPM)	8.4	6.7	6.1	5.1	4.3	3.9	3.8	3.4	3.0
RUTG-64 Water Flow (GPM)	6.4	5.6	5.1	4.2	3.6	3.3	3.2	2.8	2.5

Above estimates are for sizing purposes only.

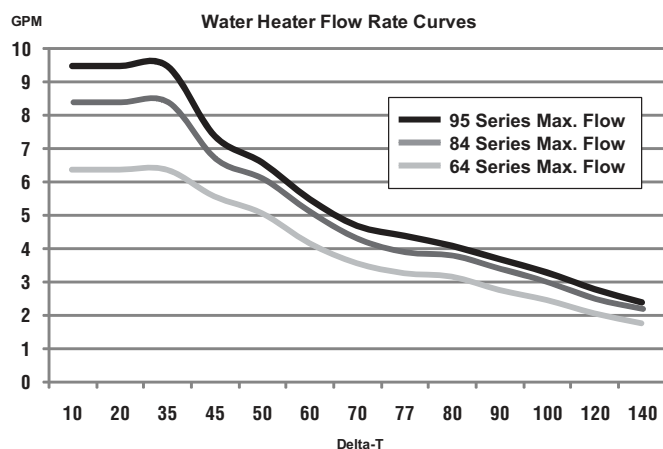

### Maximum Vent Length (intake/outlet):

Number of 90° Elbows	Maximum Length of Straight Pipe
1	39.0 ft. (12.0 m)
2	37.5 ft. (11.5 m)
3	36 ft. (11 m)
4	34.5 ft. (10.5 m)
5	33.0 ft. (10.0 m)
6	31.5 ft. (9.5 m)

(Manufacturer approved venting required)

## Parts and Accessories

Venting & terminations, recess boxes, pipe covers, extra remote controls, EZ-Link™, manifolds and cables, service valve kits, service parts and flush kits

For more information on Tankless parts and accessories, see the Parts and Accessories Catalog or call 866-720-2076.

## ACCESSORIES

**EXTERNAL BOTTOM FILTER RACK:** RXHF-14, 17, 21, 24

**EXTERNAL SIDE FILTER RACK:** RXHF-H

FILTER RACK FILTER SIZES* INCHES [mm]		
MODEL	RXHF (BOTTOM)	RXHF-H (SIDE)
RW1*04A (RXHF-14)	15 <sup>3</sup> / <sub>4</sub> x 25 [400 x 635]	15 <sup>3</sup> / <sub>4</sub> x 25 [400 x 635]
RW1*06A (RXHF-17)	15 <sup>3</sup> / <sub>4</sub> x 25 [400 x 635]	15 <sup>3</sup> / <sub>4</sub> x 25 [400 x 635]
RW1*08A (RXHF-21)	22 <sup>3</sup> / <sub>4</sub> x 25 [578 x 635]	15 <sup>3</sup> / <sub>4</sub> x 25 [400 x 635]
RW1*10A (RXHF-24)	22 <sup>3</sup> / <sub>4</sub> x 25 [578 x 635]	15 <sup>3</sup> / <sub>4</sub> x 25 [400 x 635]

\*Filter racks are shipped without filters.







Filters shipped with hydronic air handler may be used or a suitable  
1" [25.4 mm] filter.

[ ] Designates Metric Conversions

## TANKLESS WATER HEATER ACCESSORIES

Visit [RuudTankless.com](http://RuudTankless.com) for a current listing of Ruud Tankless accessories.

# Typical Piping Arrangement for Direct Space Heating and Domestic Water Supply with Tankless

KEY			
	3/4" Ball Valve(BV)		Circulating Pump
	Check Valve		Pressure Relief Valve
	3/4" Union		Tempering Valve
	Drain Valve(DV)	<b>All piping to be 3/4 inch.</b>	

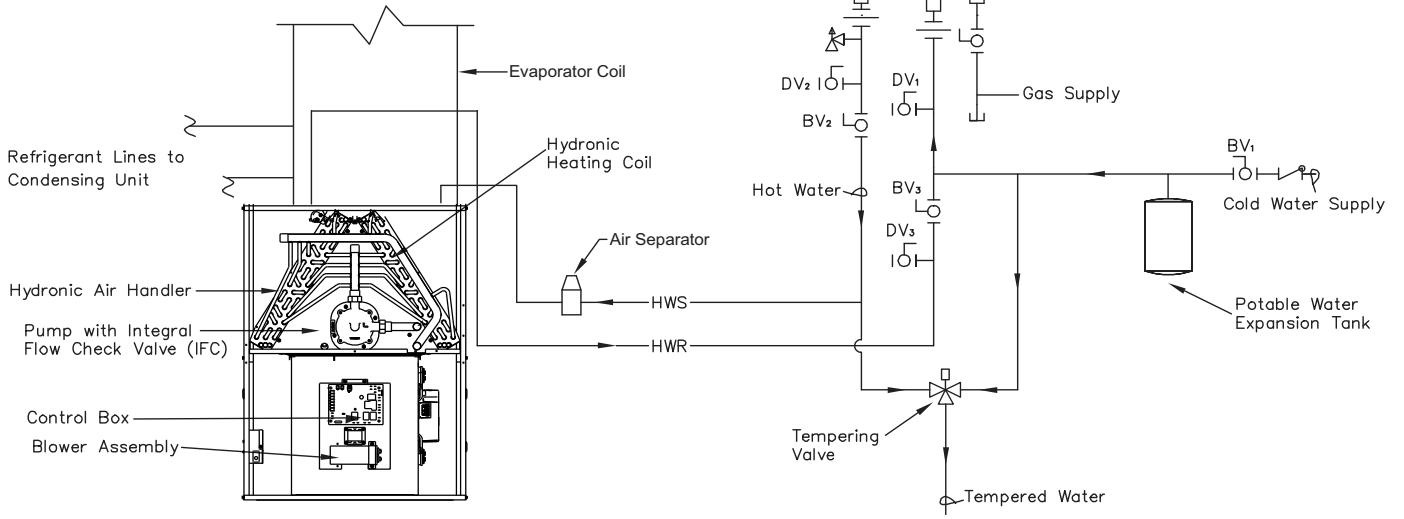

**GENERAL TERMS OF LIMITED WARRANTY\***

Ruud will furnish a replacement for any part of this product which fails in normal use and service within the applicable period stated, in accordance with the terms of the limited warranty.

**\*For complete details of the Limited and Conditional Warranties, including applicable terms and conditions, contact your local contractor or the Manufacturer for a copy of the product warranty certificate.**

Labor\* .....One (1) Year  
Air Handler Heat Exchanger/Coil\* .....Five (5) Years  
Any Other Part\* .....Five (5) Years









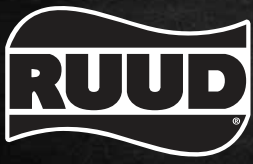

*In keeping with its policy of continuous progress and product improvement, Ruud reserves the right to make changes without notice.*

Ruud Heating, Cooling & Water Heating • P.O. Box 17010  
Fort Smith, Arkansas 72917 • [www.ruud.com](http://www.ruud.com)

Ruud Canada • 125 Edgeware Road, Unit 1  
Brampton, Ontario • L6Y 0P5

**RELY ON RUUD.™**

PRINTED IN U.S.A 10/15 QG FORM NO. H22-557 REV. 1